

Pressure relief valve, pilot operated

RE 25754/04.07
Replaces: 02.03

1/8

Type ZDBK and Z2DBK

Nominal size 6
Series 1X
Maximum operating pressure 210 bar
Maximum flow 40 l/min

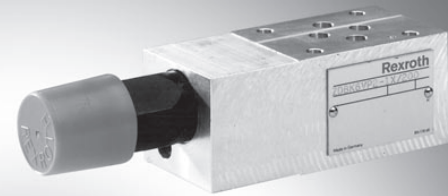

H4084

Table of contents

Contents	Page
Features	1
Order code	2
Standard types	2
Symbols	3
Function, section	3
Technical data	4
Characteristic curves	4
Dimensions	5 to 8

Features

- Sandwich plate valve
- Porting pattern to ISO 4401-03-02-0-05 (**with** locating bore)
- 3 pressure stages, optional
- 5 effective directions, optional
- With 1 or 2 pressure valve cartridges
- Adjustment element:
Sleeve with hexagon and protective cap

Information on available spare parts:
www.boschrexroth.com/spc

Order code

Z		DBK	6		2	-1X/	V	*
---	--	-----	---	--	---	------	---	---

Sandwich plate

= Z

1 pressure valve cartridge = No code
(only with variant "VA", "VB"
and "VP")

2 pressure valve cartridges = 2
(only with variant "VC" and "VD")

Pressure relief valve = DBK

Size 6 = 6

Relief function from – to:

A – T = VA

P – T = VP

B – T = VB

A – T and B – T = VC

A – B and B – A = VD

Adjustment element for pressure adjustment

Sleeve with hexagon and protective cap = 2

Further details in clear text

Seal material

FKM seals
(other seals on request)

⚠ Attention!

Observe compatibility of seals with
hydraulic fluid used!

Pressure setting

50 = Pressure setting up to 50 bar

100 = Pressure setting up to 100 bar

210 = Pressure setting up to 210 bar

1X = Component series 10 to 19
(10 to 19: unchanged installation and connection dimensions)

Standard types

Type ZDBK	Material number
ZDBK 6 VA2-1X/50V	R900564557
ZDBK 6 VA2-1X/100V	R900501402
ZDBK 6 VA2-1X/210V	R900564558
ZDBK 6 VB2-1X/50V	R900564559
ZDBK 6 VB2-1X/100V	R900564560
ZDBK 6 VB2-1X/210V	R900564561
ZDBK 6 VP2-1X/50V	R900564562
ZDBK 6 VP2-1X/100V	R900564563
ZDBK 6 VP2-1X/210V	R900564564

Type Z2DBK	Material number
Z2DBK 6 VC2-1X/50V	R900565005
Z2DBK 6 VC2-1X/100V	R900565006
Z2DBK 6 VC2-1X/210V	R900565007
Z2DBK 6 VD2-1X/50V	R900565002
Z2DBK 6 VD2-1X/100V	R900565003
Z2DBK 6 VD2-1X/210V	R900564570

Symbols (1) = valve side, (2) = subplate side)

Type ZDBK 6 VA...

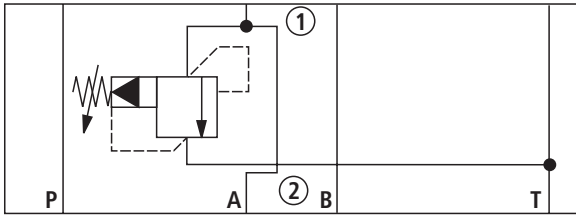

Type ZDBK 6 VB...

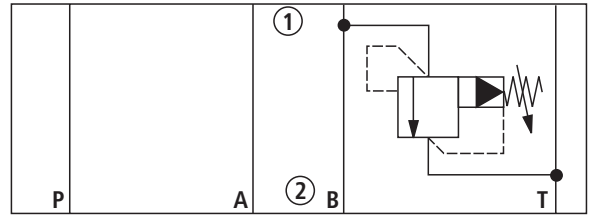

Type ZDBK 6 VP...

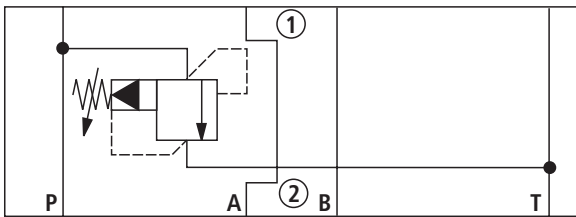

Type Z2DBK 6 VC...

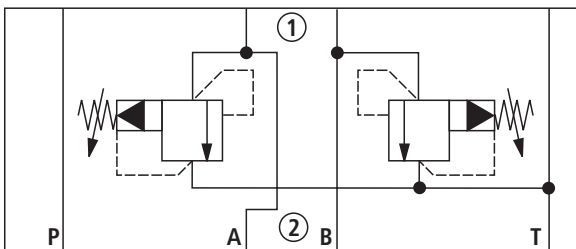

Type Z2DBK 6 VD...

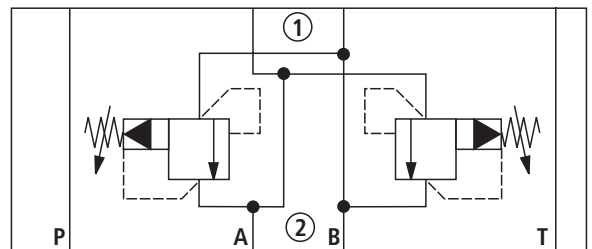

Function, section

ZDBK and Z2DBK pressure relief valves are pilot operated pressure relief valves of sandwich plate design. They are used to limit a system pressure.

The valves basically consist of a housing (7) and one or two pressure valve cartridges. The system pressure is set via the adjustment element (4).

At rest the valves are closed. The pressure in port A acts on the spool (1). At the same time the pressure is applied via the orifice (2), onto the spring loaded side of the spool (1) and via orifice (3) onto the pilot poppet (6). If the pressure in port A

rises above the value set at the spring (5) then the pilot poppet (6) opens. Pressure fluid flows from the spring loaded side of the spool (1), orifice (3) and bore (8) into port T. The resulting pressure drop moves the spool (1) and thus opens the connection A to T while maintaining the pressure set at the spring (5).

The pilot oil return from both spring chambers is externally via port T.

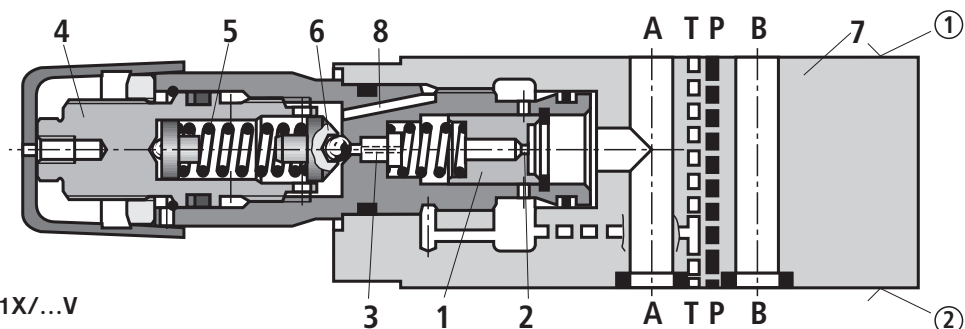

Type ZDBK 6 VA2-1X/...V

Technical data (for applications outside these parameters, please consult us!)**General**

Weight	Type ZDBK	kg	Approx. 0.6
	Type Z2DBK 6 VC	kg	Approx. 0.8
	Type Z2DBK 6 VD	kg	Approx. 1.4
Installation orientation			Optional
Ambient temperature range			°C -20 to +80

General

Maximum operating pressure	bar	210
Maximum pressure setting	bar	50; 100; 210
Maximum counterpressure (port T)	bar	< 100
Maximum flow	l/min	40
Hydraulic fluid	Minera oil (HL, HLP) to DIN 51524; fast bio-degradable hydraulic fluids to VDMA 24568 (see also RE 90221); HETG (rape seed oil); HEPG (polyglycols); HEES (synthetic esters); other hydraulic fluids on request	
Pressure fluid temperature range	°C	-20 to +80
Viscosity range	mm ² /s	10 to 800
Max. permissible degree of contamination of the hydraulic fluid - cleanliness class to ISO 4406 (c)	Class 20/18/15 ¹⁾	

¹⁾ The cleanliness class stated for the components must be adhered to in hydraulic systems. Effective filtration prevents faults from occurring and at the same time increases the component service life.

For the selection of filters, see catalogue sheets RE 50070, RE 50076, RE 50081, RE 50086, RE 50087 and RE 50088.

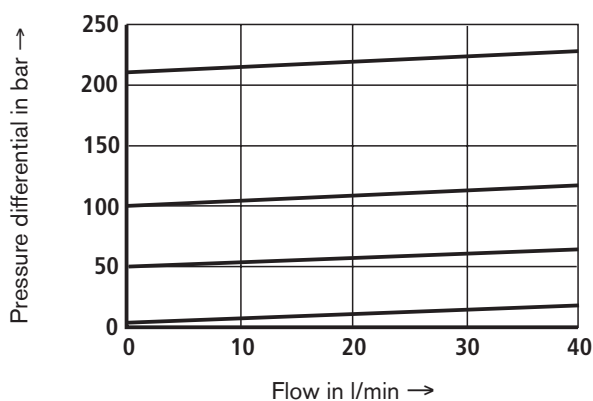
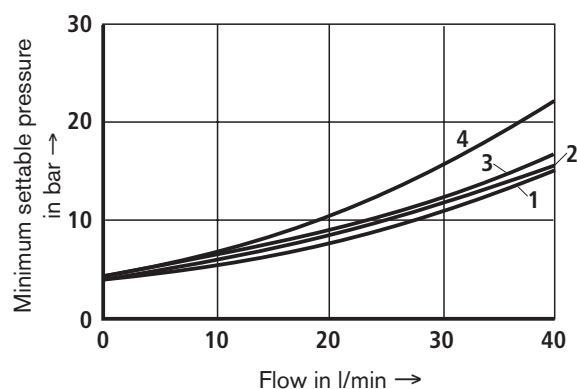
Characteristic curves (measured with HLP46 and $\vartheta_{oil} = 40 \text{ °C} \pm 5 \text{ °C}$) $p_E - q_V$ - characteristic curves $p_{E \min} - q_V$ - characteristic curves

- 1 VA, VB, VC
- 2 VD (A to B)
- 3 VP
- 4 VD (B to A)

The characteristic curves are valid for output pressure = zero over the complete flow range!

Dimensions: Type ZDBK 6 VA and ZDBK 6 VP (dimensions in mm)

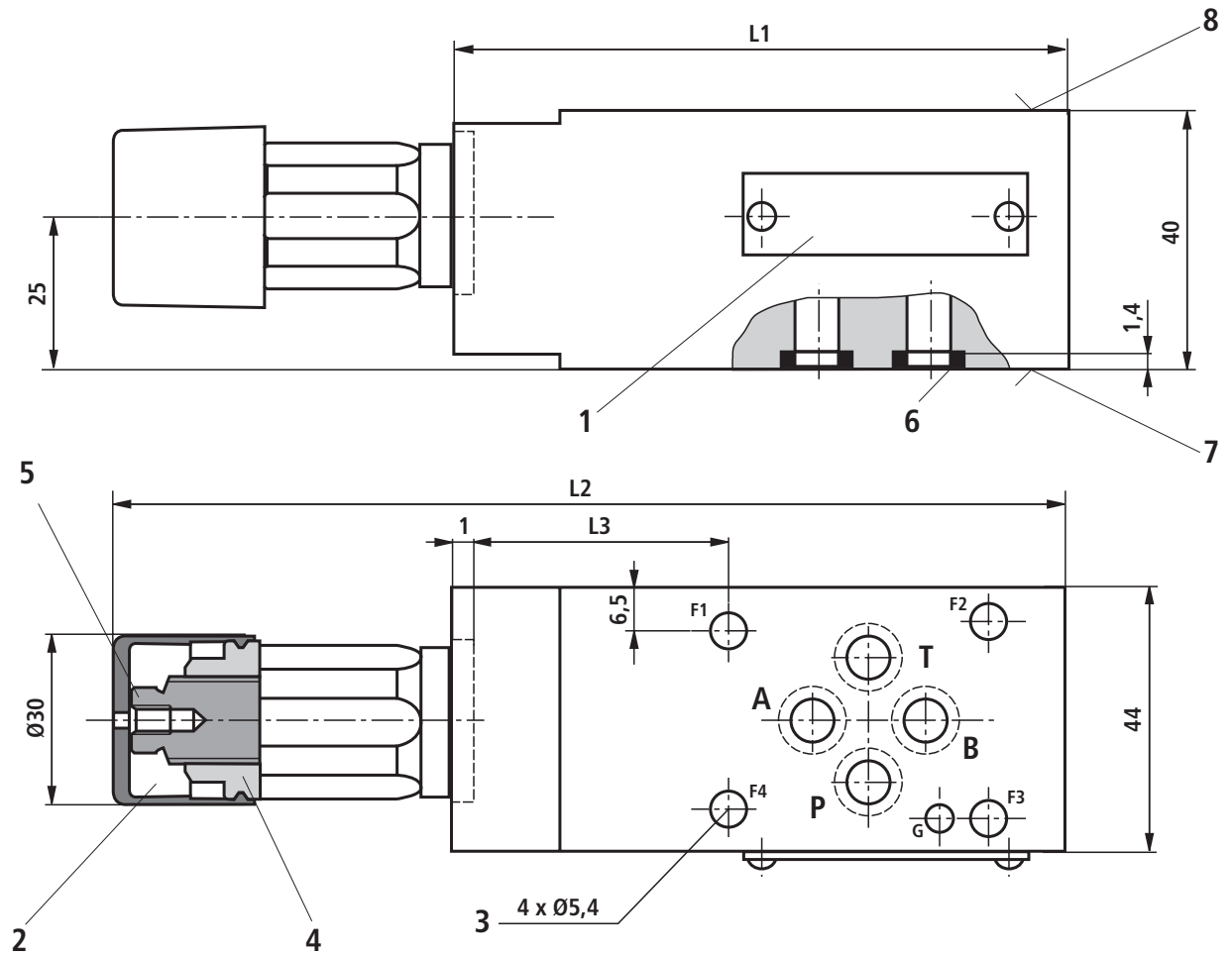

Type	L1	L2	L3
ZDBK 6 VA	88	148	34,5
ZDBK 6 VP	100	160	46,5

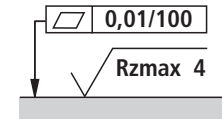

Required surface quality of the valve mounting face

- 1 Nameplate
- 2 Adjustment element: Sleeve with hexagon and protective cap
- 3 Valve mounting bores
- 4 Locknut 24 A/F
- 5 Hexagon 10 A/F
- 6 Identical seal rings for ports A, B, P, T (plate side)
- 7 Plate side – porting pattern to ISO 4401-03-02-0-05 (with locating bore for locating pin ISO 8752-3x8-St, material no. **R900005694**, separate order)
- 8 Component side – porting pattern to ISO 4401-03-02-0-05 (with locating bore Ø4 x 4 mm deep)

Valve fixing screws (separate order)

- 4 hexagon socket head cap screws ISO 4762 - M5 - 10.9-fIZn-240h-L
Friction coefficient $\mu_{total} = 0.09$ to 0.14 ,
tightening torque $M_T = 7 \text{ Nm} \pm 10\%$,
or
- 4 hexagon socket head cap screws ISO 4762 - M5 - 10.9
Friction coefficient $\mu_{total} = 0.12$ to 0.17 ,
tightening torque $M_T = 8.1 \text{ Nm} \pm 10\%$

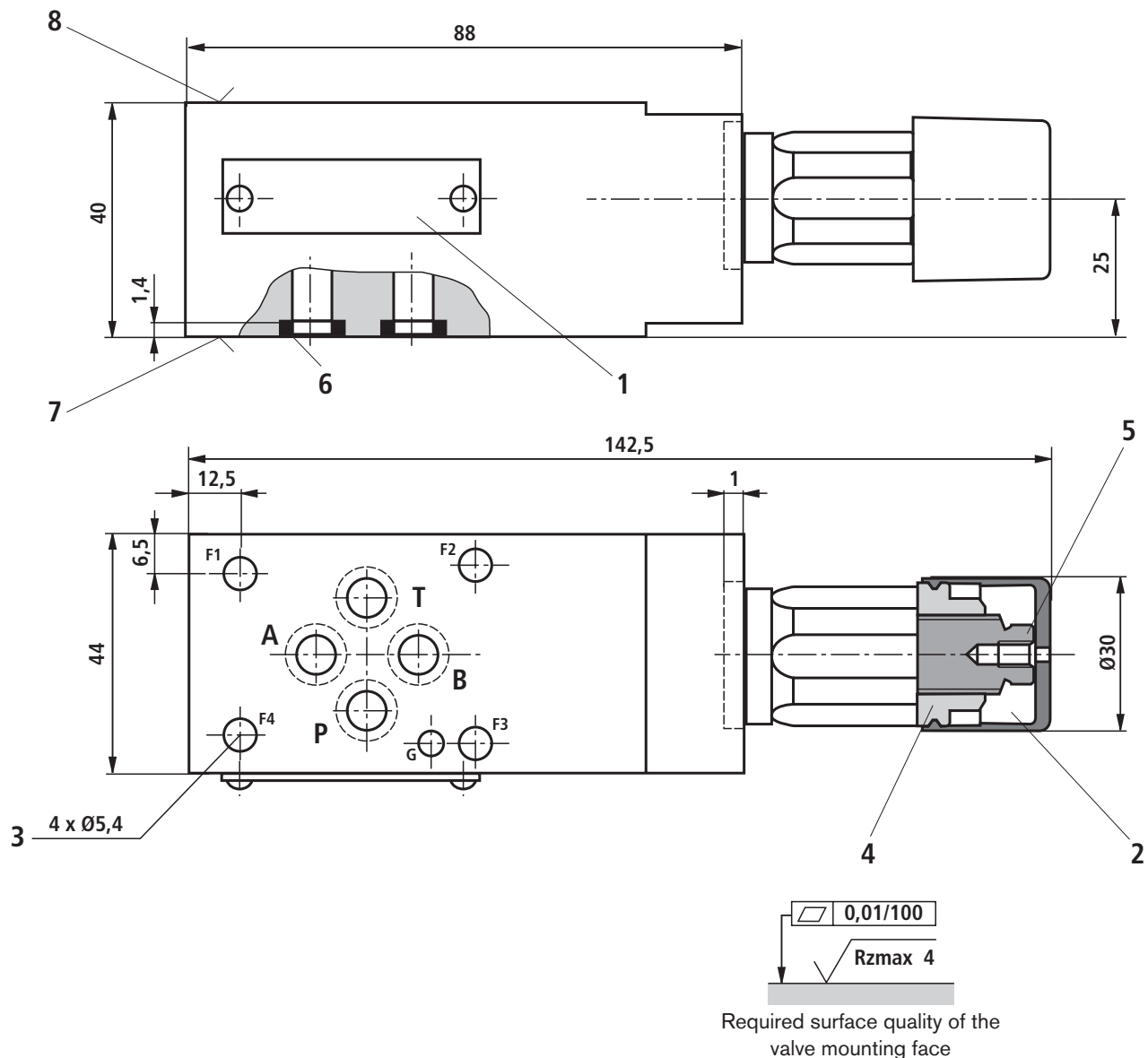
Dimensions: Type ZDBK 6 VB (dimensions in mm)

- 1 Nameplate
- 2 Adjustment element: Sleeve with hexagon and protective cap
- 3 Valve mounting bores
- 4 Locknut 24 A/F
- 5 Hexagon 10 A/F
- 6 Identical seal rings for ports A, B, P, T (plate side)
- 7 Plate side – porting pattern to ISO 4401-03-02-0-05 (with locating bore for locating pin ISO 8752-3x8-St, material no. **R900005694**, separate order)
- 8 Component side – porting pattern to ISO 4401-03-02-0-05 (with locating bore Ø4 x 4 mm deep)

Valve fixing screws (separate order)

– 4 hexagon socket head cap screws
ISO 4762 - M5 - 10.9-fIZn-240h-L
 Friction coefficient $\mu_{\text{total}} = 0.09$ to 0.14 ,
 tightening torque $M_T = 7 \text{ Nm} \pm 10\%$,
 or

– 4 hexagon socket head cap screws **ISO 4762 - M5 - 10.9**
 Friction coefficient $\mu_{\text{total}} = 0.12$ to 0.17 ,
 tightening torque $M_T = 8.1 \text{ Nm} \pm 10\%$

Dimensions: Type Z2DBK 6 VC (dimensions in mm)

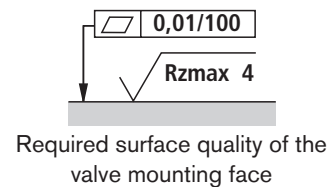
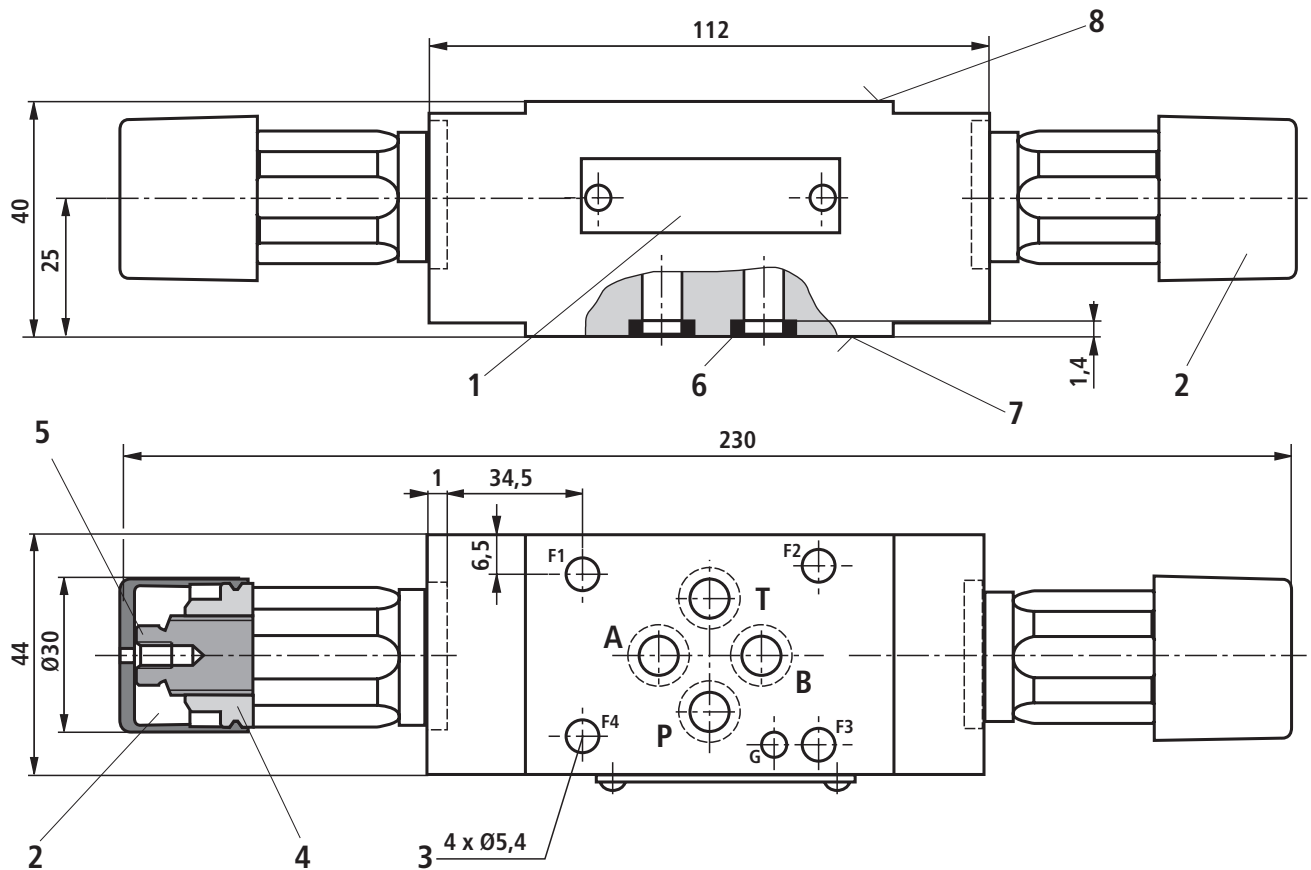

- 1 Nameplate
- 2 Adjustment element: Sleeve with hexagon and protective cap
- 3 Valve mounting bores
- 4 Locknut 24 A/F
- 5 Hexagon 10 A/F
- 6 Identical seal rings for ports A, B, P, T (plate side)
- 7 Plate side – porting pattern to ISO 4401-03-02-0-05 (with locating bore for locating pin ISO 8752-3x8-St, material no. **R900005694**, separate order)
- 8 Component side – porting pattern to ISO 4401-03-02-0-05 (with locating bore Ø4 x 4 mm deep)

Valve fixing screws (separate order)

- 4 hexagon socket head cap screws
ISO 4762 - M5 - 10.9-fIZn-240h-L
Friction coefficient $\mu_{\text{total}} = 0.09$ to 0.14 ,
tightening torque $M_T = 7 \text{ Nm} \pm 10\%$,
or

- 4 hexagon socket head cap screws **ISO 4762 - M5 - 10.9**
Friction coefficient $\mu_{\text{total}} = 0.12$ to 0.17 ,
tightening torque $M_T = 8.1 \text{ Nm} \pm 10\%$

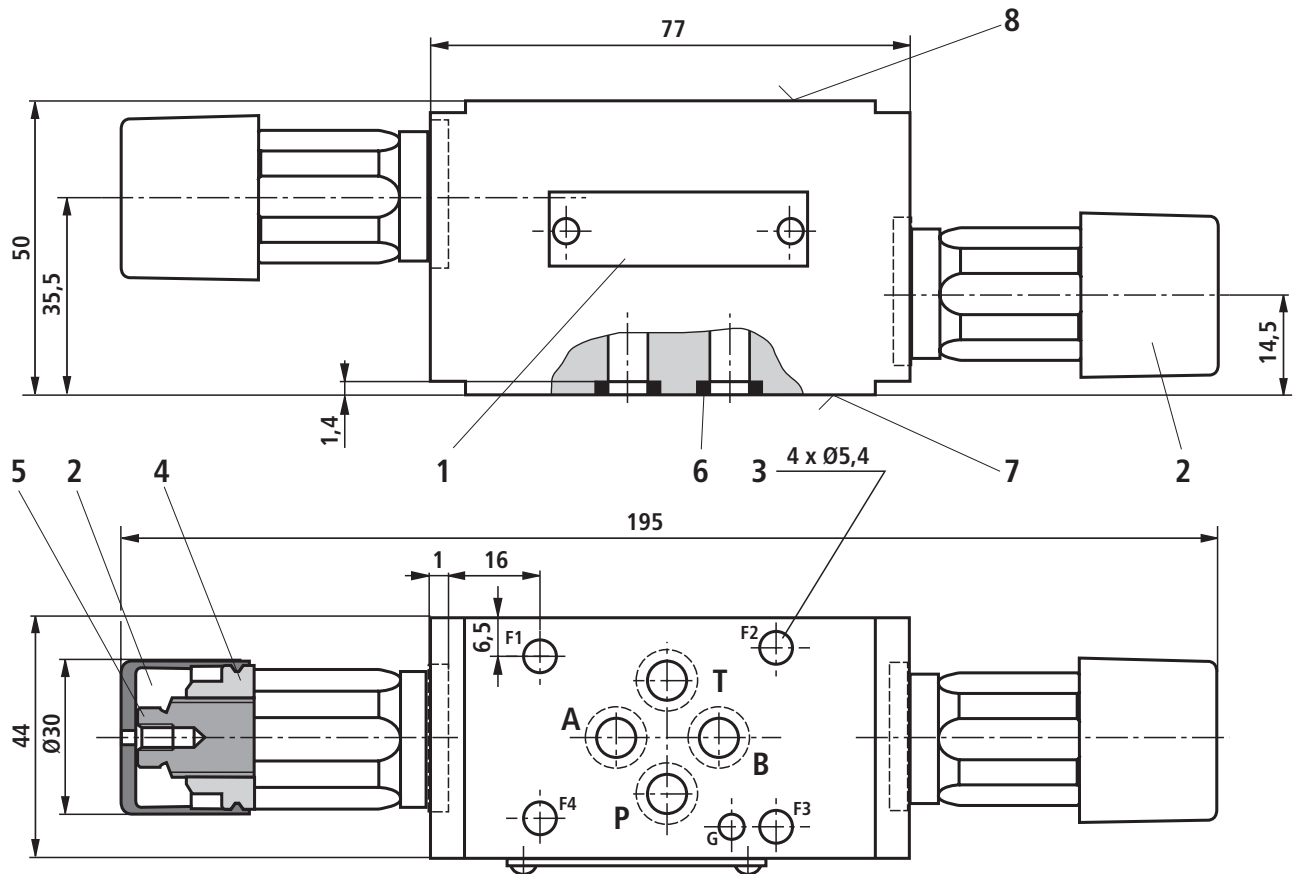
Dimensions: Type Z2DBK 6 VD (dimensions in mm)

- 1 Nameplate
- 2 Adjustment element: Sleeve with hexagon and protective cap
- 3 Valve mounting bores
- 4 Locknut 24 A/F
- 5 Hexagon 10 A/F
- 6 Identical seal rings for ports A, B, P, T (plate side)
- 7 Plate side – porting pattern to ISO 4401-03-02-0-05 (with locating bore for locating pin ISO 8752-3x8-St, material no. **R900005694**, separate order)
- 8 Component side – porting pattern to ISO 4401-03-02-0-05 (with locating bore Ø4 x 4 mm deep)

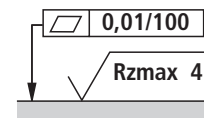

Required surface quality of the valve mounting face

Valve fixing screws (separate order)**– 4 hexagon socket head cap screws****ISO 4762 - M5 - 10.9-fIZn-240h-L**

Friction coefficient $\mu_{\text{total}} = 0.09$ to 0.14 ,
tightening torque $M_T = 7 \text{ Nm} \pm 10\%$,
or

– 4 hexagon socket head cap screws ISO 4762 - M5 - 10.9

Friction coefficient $\mu_{\text{total}} = 0.12$ to 0.17 ,
tightening torque $M_T = 8.1 \text{ Nm} \pm 10\%$