

Check Valve, Ball Type, Pilot to Open

RJV1-05

M24x1.5 • Q_{max} 20 l/min (5 GPM) • p_{max} 250 bar (3600 PSI)

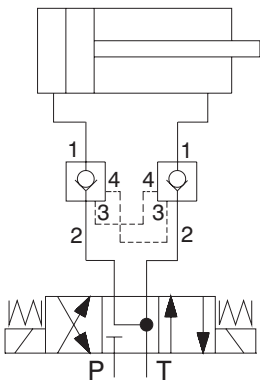
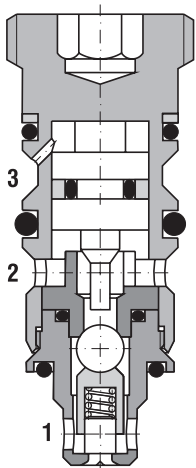

Hydraulic circuit with two pilot operated check valves. If pressured, the respective valve will pilot the other to open, thereby enabling cylinder motion in both directions. Without pressure at either valve, the cylinder is locked in place. (see application picture)

Technical Features

- › Hardened precision parts
- › Sharp-edged steel seats for dirt-tolerant performance
- › Leak-free closing, suitable for fast cycling with long life
- › High flow capacity
- › Optional sealed piston and flow restrictor integrated in hollow bolt
- › Design suitable for direct cylinder mounting through hollow bolt
- › In the standard version, the valve is zinc-coated for 240 h protection acc. to ISO 9227

Functional Description

The valve allows flow to pass from port 2 to 1 while under load normally inhibiting flow from 1 to 2. When pressure is applied at port 3, flow passes from port 1 to 2.

The cartridge valve has a pilot ratio of 5.76:1, meaning that a minimum of 17 % of the load pressure must be applied at port 3 to open the valve. The check valve is spring closed to secure the holding position in static conditions and without load. The valve is optionally offered with a sealed piston and a flow restrictor valve. Port 4 is available for use in double acting applications using two pilot operated check valves.

Model Code	RJV1-05	S	J1	J2
Symbol				

Technical Data

Valve size / Cartridge cavity		M24x1.5 / Q13
Max. flow	l/min (GPM)	20 (5.3)
Max. operating pressure	bar (PSI)	250 (3630)
Pilot ratio		5.76:1
Fluid temperature range (NBR)	°C (°F)	-30 ... +100 (-22 ... +212)
Fluid temperature range (FPM)	°C (°F)	-20 ... +120 (-4 ... +248)
Mass of the cartridge valve	kg (lbs)	0.08 (0.18)
Mass of the cartridge valve with body	kg (lbs)	1.6 (3.53)

	Datasheet	Type
General information	GI_0060	Products and operating conditions
Cavity details	SMT_0019	SMT-Q13*
Spare parts	SP_8010	

Characteristics measured at $v = 32 \text{ mm}^2/\text{s}$ (156 SUS)

Pressure drop related to flow rate

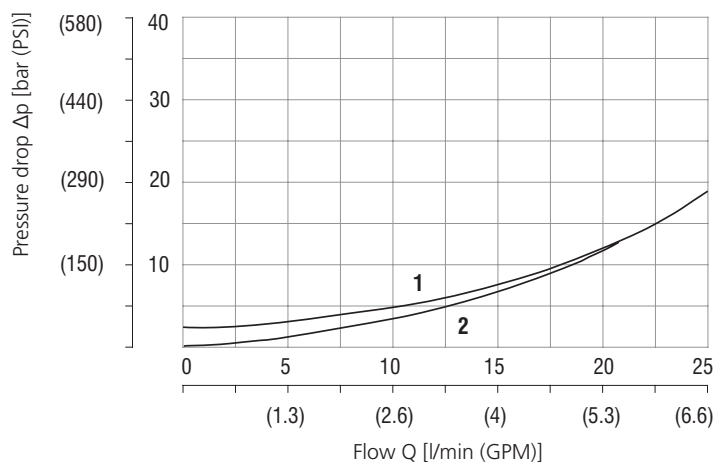

1	free flow (2→1)
2	pilot open (1→2)

Dimensions in millimeters (inches)

Cartridge valve RVJ1-05

Model with body and hollow bolt RVJ1-05*M(G)/* S, J1, J2

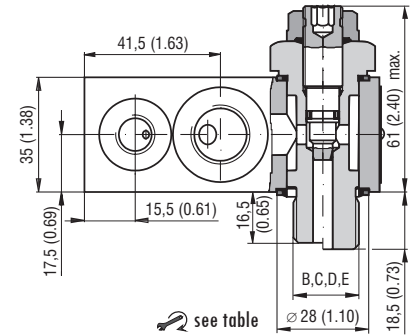
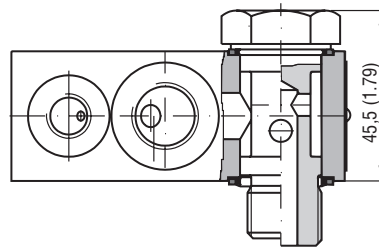
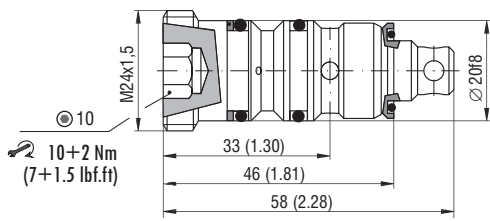

Model M

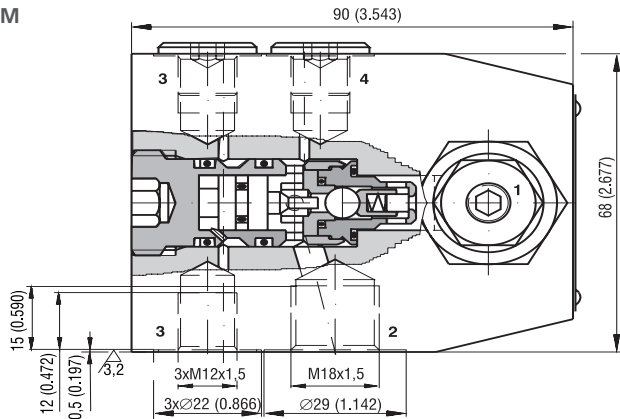

Type	Port size	Ø D max mm (in)	Tightening torque Nm (ft-lbf)
B	M18x1.5	18 ^{+0,2} (0.708 / 0.716)	30+3 (22.13+2.21)
C	M22x1.5	22 ^{+0,2} (0.866 / 0.874)	70+5 (51.63+3.69)
D	G1/2	21 ^{+0,2} (0.826 / 0.834)	70+5 (51.63+3.69)
E	G3/8	16,6 ^{+0,2} (0.653 / 0.661)	25+3 (18.43+2.21)

Model G

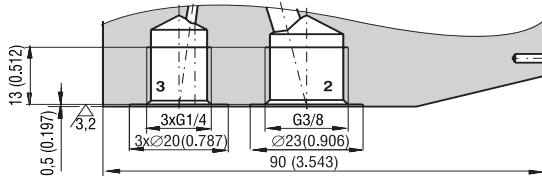

Ordering Code

RVJ1-05 / -

Check valve, pilot to open, ball type

Valve size

Pilot piston seal
without seal
with seal

Model
Cartridge valve
with body - metric threads
with body - BSP threads

No designation
S

No designation
M
G

Surface treatment
No designation body and flow restrictor phosphated, check valve black-coated and hollow bolt zinc-coated (ZnCr-3), ISO9227 (240 h)
A parts zinc-coated (ZnCr-3), ISO 9227 (240 h)
B parts zinc-coated (ZnNi), ISO 9227 (520 h)

Seals
No designation
V NBR
FPM (Viton)

Hollow bolt
only for models with valve body
No designation without flow restrictor
S with flow restrictor VSV1
J1 with flow restrictor VSVJ01 and check valve
J2 with flow restrictor VSVJ1 and check valve - reversed

Hollow bolt threads
only for models with valve body
B M18x1.5
C M22x1.5
D G1/2
E G3/8